

STEP SCREENS SSR

In-Channel Screens for separation of solids from wastewaters

MACHINE DESCRIPTION

The fine step screen separates and collects efficiently solids from wastewater. The step screen has a small footprint, which assists installation and maintenance, and connection to existing continuation processes.

The **SSR** is enclosed to eliminate nuisance from odour and splashing. The high upstream/downstream screening ability is based on the sieving effect of the screen mat. The screen mat is not removed immediately, but is used to further capture particles. The level differential (**or timer control**) starts and stops the step screens.



WORKING LOGIC FOR IN-CHANNEL STEP SCREENS SSR

The screened materials are raised one step at a time to the top of the bars, and ultimately discharged to a pressing or receptacle conveyor. The hook-like shape of the steps effectively prevents the screened materials from dropping backwards and the shape of the underside of the bars stops solid matter from collecting under the bars minimizing maintenance.

The screen has no mechanism that forces screened materials between the lamella. Available lamella spacing is **1 - 10 mm**. The step screen is manufactured in stainless acid-resistant steel (**AISI 304 St.St.**, **AISI 316 St.St.**).

AUXILIARY EQUIPMENT

R.E.M. also manufactures screening conveyors and screening presses which can be integrated to the screen control itself.



MAIN FEATURES FOR STEP SCREENS SSR
SSR step screens have the following characteristics:

1. Standard execution in st. st. AISI 304/AISI 316.
2. No mechanical parts in direct contact to conveyed products.
3. Low speed - No blocking or clogging even when extracting fibrous materials.
4. Completely sealed unit outside of the channel for leakage and odour-free environments.
5. Possibility to discharge in dumpsters or other equipment.
6. Extremely easy to transport materials even of difficult composition.
7. Maximum versatility, high processing outputs.
8. Drive Chain entirely made of stainless steel.

n.b.: the manufacturer may modify some dimensions or sizes without prior information

STANDARD DIMENSION DATA FOR IN-CHANNEL STEP SCREENS SSR

In this section all technical and dimension data and main features for the step screens manufactured by R.E.M.



ATTENTION THE MACHINE CAN BE USED IN THE INCLINED POSITION UP TO A MAX. OF 75°

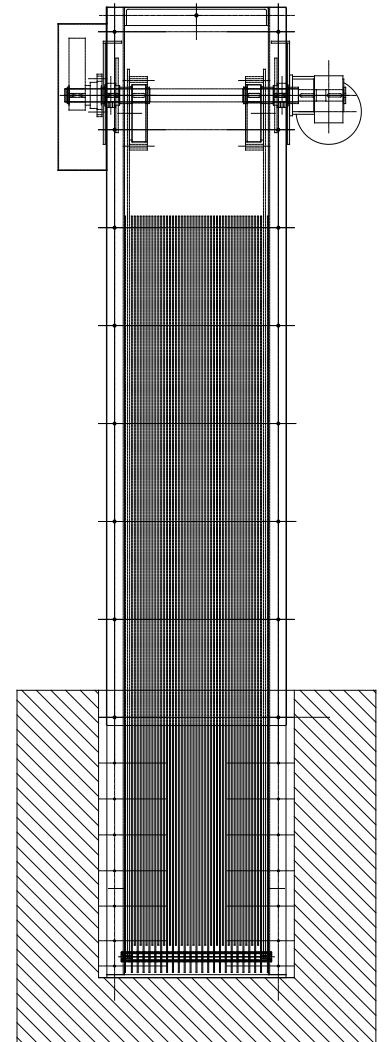
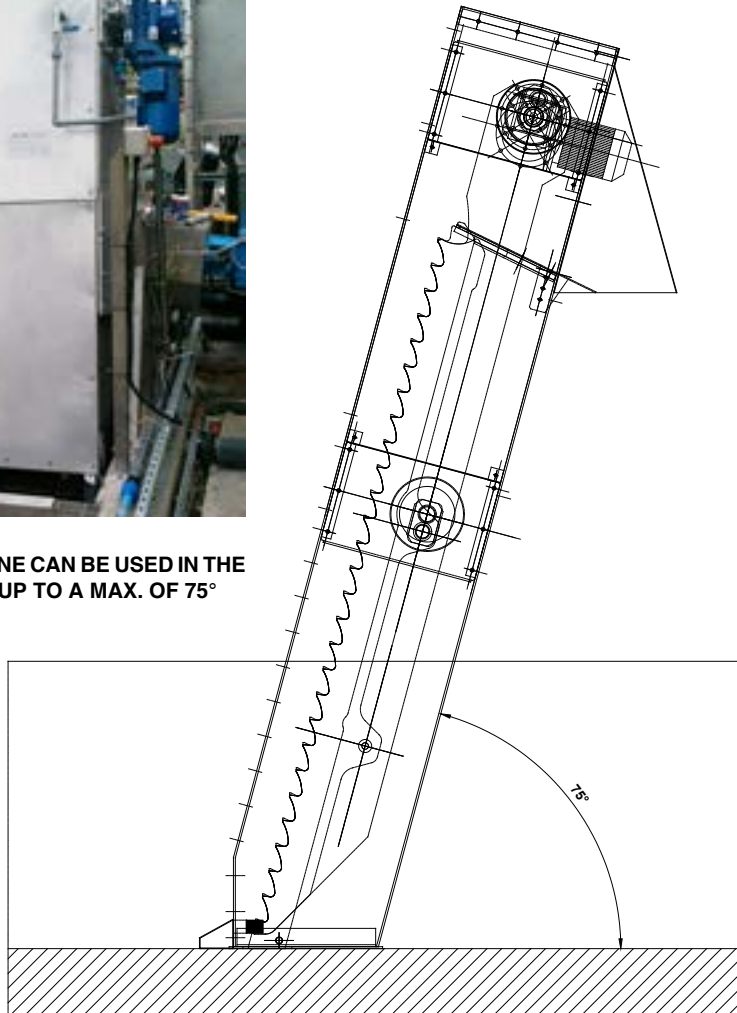

SSR MODELS	SSR300	SSR400	SSR500	SSR600	SSR700	SSR800	SSR900
DISCHARGE HEIGHT FROM INVERT - mm	2500	2500	2500	2500	2500	2500	2500
SCREEN NET WIDTH - mm	125	225	325	425	525	625	725
CHANNEL WIDTH - mm	300	400	500	600	700	800	900

MATERIAL: SCREENINGS

Fabricated parts material:

*Stainless Steel AISI304 / *Stainless Steel AISI316

Panels material:

*Stainless Steel AISI304 / *Stainless Steel AISI316