

REMSCREEN RS4

Externally fed Drum Screens

MACHINE DESCRIPTION

R.E.M. range of drum screens for removal of screenings offers a broad selection where units for every application can be found. The range includes different size models that can vary in accordance with customer needs.

The models are all based on the same technology. The filtration occurs by letting the water pass through the drum while solids are captured and conveyed upwards toward the scraping doctor blade. The drum screen is recommended for small wastewater treatment plants both industrial and municipal wherever microfiltration (**250 microns to 2,5 mm- all wedge wire screens**) is required.

WORKING LOGIC FOR FILTERING DRUM SCREENS RS4

The effluent flowing through the screen deposits the solids on the screen surface that is slowly rotating and the screened materials travel within the drum toward its discharge.

The stationary scraper (doctor blade) removes the solids and discharges them into the collecting bin (not supplied). The screened effluent is collected in a chamber located beneath the drum. The drained water generated can be used for washwater purposes. Drum screens are made of the following sections:

- Rotary drum.
- Drained water collecting tank.
- Supporting frame.
- Drive unit.



MAIN FEATURES FOR FILTERING DRUM SCREENS RS4

1. Screen available with wedge wire type openings in various sizes.
2. The machine is cleaned by the doctor blade and the washing system installed inside the drum.
3. The wide range available allows to choose the suitable version for the application requirements.
4. The stainless steel structure allows to install the unit for handling acids, basic products and foodstuffs.
5. Entire operation of the machine is handled by the drive units.
6. Installation is easy and rapid.
7. Maintenance operations, if necessary, are very simple.

APPLICATION ADVANTAGES FOR FILTERING DRUM SCREENS RS4

The following details, for purposes of information and reference, provide some information of a standard nature concerning the advantages of applying this model of screen.

1. **Screen open area:** The open area can be up to 65% (according to the aperture).
2. **Solids separation capacity:** It is able to reach a percentage of solids/liquids separation greater than 60%.
3. **Head loss:** Minimum head loss thanks to the rotary drum.
4. **Construction material:** The RS4 screens are made entirely of corrosion-resistant stainless steel.



STANDARD DIMENSION DATA FOR FILTERING DRUM SCREENS RS4

Here we provide some information of a technical nature for this type of screens.

RS4 MODELS	RS450/6	RS470	RS4100	RS4130	RS4160	RS4200	RS4300
LENGTH SCREEN - A mm	1200	1200	1200	1200	1200	1200	1300
WIDTH SCREEN - B mm	950	1150	1450	1750	2050	2450	3450
HEIGHT SCREEN - C mm	1460	1460	1460	1460	1460	1460	1560
Hydraulic Flow m ³ /h - Wedge wire 0.5	99	138	198	250	316	390	731
Hydraulic Flow m ³ /h - Wedge wire 1	165	230	330	427	528	660	1221
Hydraulic Flow m ³ /h - Wedge wire 1.5	210	291	425	544	672	835	1554
Hydraulic Flow m ³ /h - Wedge wire 2	215	299	428	556	688	855	1590

ATTENTION CAPACITY IS REFERRED TO EFFLUENT AT 200 PPM DS.

Materials of Construction:

Fabricated parts: AISI Stainless Steel 304 / Stainless Steel 316 - Rotary screen: AISI Stainless Steel 304 / Stainless Steel 316

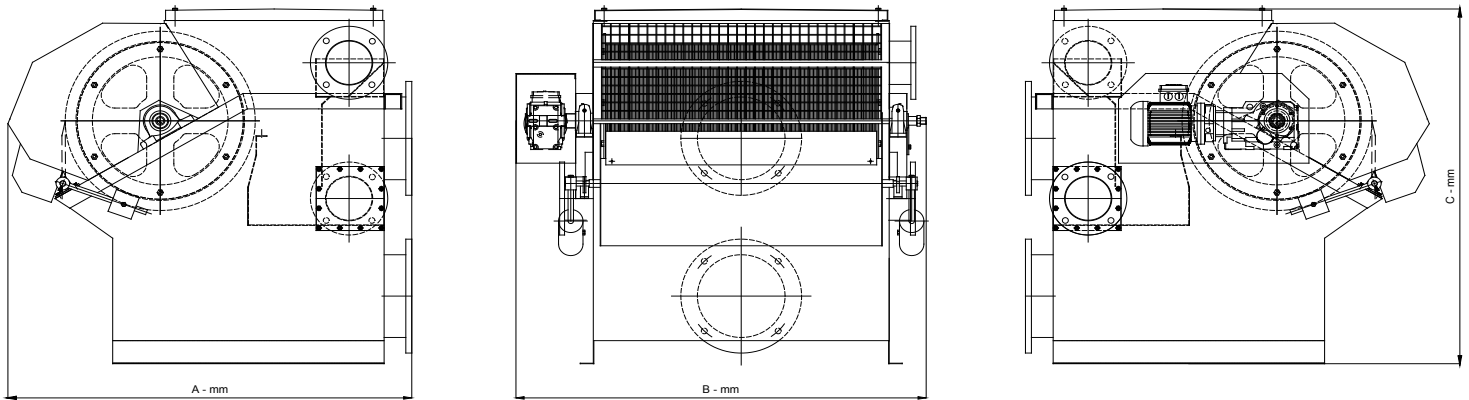

n.b.: the manufacturer may modify some dimensions or sizes without prior information

