

COMBY PLANTS RCT2

Compact Systems for pre-treatment of cesspool-interceptor septage



MACHINE DESCRIPTION

The septage acceptance unit is a system studied to receive and mechanically pre-treat effluents from cesspools with a single compact unit. The sludges, discharged from tanker trucks, are filtrate to remove large particles, thus sand is settled and washed. The conditioned effluent is afterwards discharged into the biological wastewater treatment plant.

WORKING LOGIC FOR COMBY PLANTS RCT2

Tanker trucks get connected to the unit through a flex hose DN.100 and clamped by a quick spherical connection. Solid large particles included in the waste are captured and removed by the inlet fine screw screen. The screw removes and compacts the screenings before discharge. Along the conveying section is installed a washing system consisting of a set of nozzles where pressurised water is sprayed into the screenings themselves.

The washing system allows to remove fecal matter from the screenings discharging a neat solid which can be landfilled without bothering of smells or leakages. At the discharge a built-in compactor is installed reducing the screenings volume by up to **50%**.

Once screened the sludge enters the aerated sedimentation tank where sand deposits on the bottom of the tank, while organics are kept in suspension by the air injection. The coarse air bubbles allow to wash out the sand and allows the separation of sand having a reduced organic content. The extraction screw removes and discharges the sand into the sand bin.

MAIN ADVANTAGES FOR COMBY PLANTS RCT2

- No leaks, smells or aerosols generated by the system.
- No drives in contact with the sludge.
- Compact design and small footprint.
- No concrete casting required.
- Low operation and maintenance costs.
- Low costs for installation and erection.
- Excellent screening performance with up to 52% solids capture ratio.



GENERAL DIMENSION DATA FOR COMBY PLANTS RCT2

Here we provide some information of a technical nature for this type of screens:

- Filtration with 6 mm perforated screen.
- Removal and conveying of screenings to the discharge point with a single drive.
- Volume reduction of screenings up to 50%.
- Removal of sand (200 micron or bigger) up to 90%.
- Effective drainage of the screenings along the conveying section combined with a compaction section for more volume reduction and water removal.
- Washing of screenings performed by the REMSPRAY integrated system using 3 independent washing cycles.

R.E.M. RCT2 septage receiving stations can be equipped with the following accessories:

- vertical discharge.
- bagging (single or endless bag type).
- heat and weather protection.
- centralized solenoid valves and piping.
- control cabinet.
- ATEX or UL NEMA 7 EX-proof version.
- by-pass.
- by-pass with manual bar screen.

STANDARD DIMENSION DATA FOR COMBY PLANTS RCT2

RCT2 MODELS	A - mm	B - mm	C - mm	Ø INLET	Ø OUTLET	FLOW RATES m³/h
RCT2/15	4819	2650	1070	DN100	DN200	50
RCT2/30	6475	4870	1944	DN100	DN200	100
RCT2/60 with rotating basket screen RS2	8931	4593	1929	DN100 / DN150	DN300	200

Materials of construction for fabricated parts:

*Stainless Steel AISI304 / *Stainless Steel AISI316

Materials of construction of spiral:

*Stainless Steel AISI304

*Stainless Steel AISI316

*High resistance steel HRS

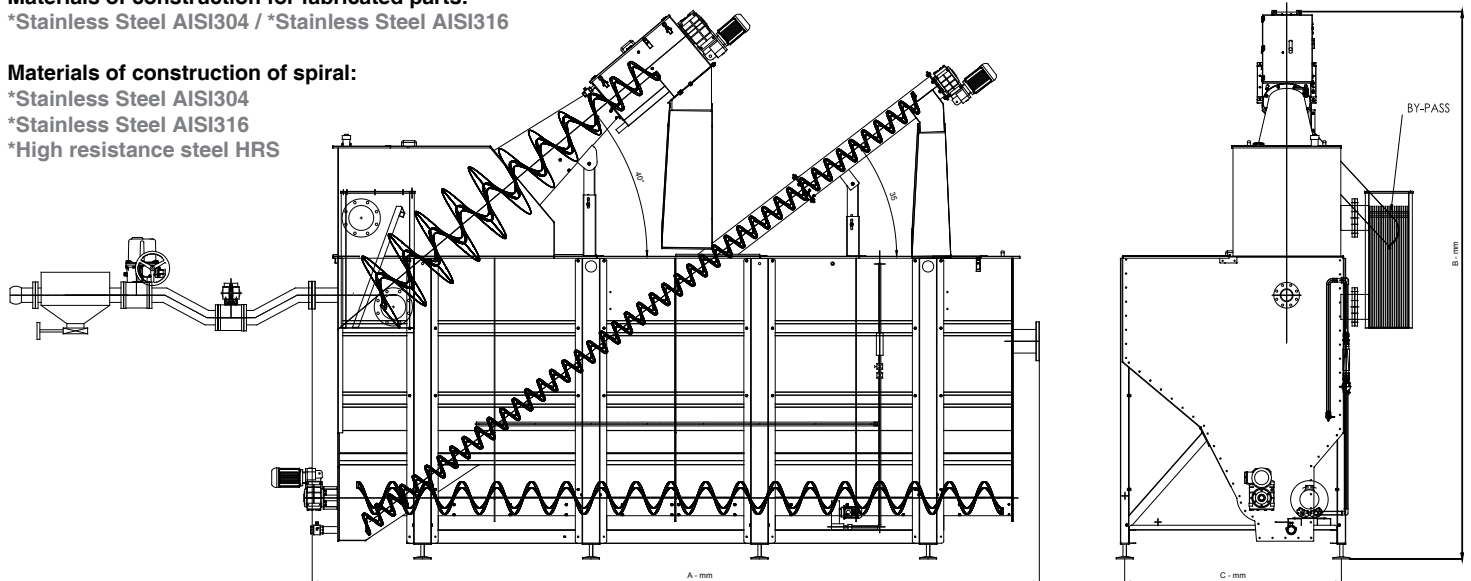

n.b.: the manufacturer may modify some dimensions or sizes without prior information

