

## PLOUGHSHARE MIXERS RMM

### Single Shaft Ploughshare mixers



#### MACHINE DESCRIPTION

**RMM** Ploughshare mixers are dedicated to mixing sludge or inerts together with additives and lime. The vortex energetic action generated by the special shape of the ploughs allows to incorporate the additives into the main media saving on the amount of additives required and increasing the quality of the final product.

The robust and rugged construction allows to perfectly homogenize also coarse particles or inerts like gravel. **R.E.M.** offers this type of machine, that can treat the following materials:

- dewatered sludges.
- screened materials containing high percentages of sands.
- solid urban waste.
- contaminated soil and inerts.

The main advantages of the **RMM** mixers are:

1. High dispersion of the additives into the media.
2. Possibility to handle materials of different sources.
3. Continuous operation.
4. Fast process.
5. Residues of minimum amount.

#### WORKING LOGIC FOR PLOUGHSHARE MIXERS RMM

Ploughshare mixers **RMM** are fed with the materials to be treated through the main inlet located on one end of the mixing chamber (drive side), the additives are inserted through a separate inlet for solids or a set of nozzles located along the cylinder for the liquids. While conveyed toward the outlet the components are mixed and lifted ensuring a perfect blend and dispersion. Liquids are completely absorbed by the product. A weir installed at the outlet allows to modify the residential time of the product and the mixing capacity. The discharge, through the outlet located opposite to the inlet, is continuous and does not require any valve. The main advantages are:

1. Possibility to handle and mix materials of different natures or sources and not constant over time.
2. Easy maintenance and cleaning.
3. Short mixing time.
4. High Throughput.

#### MAIN FEATURES OF PLOUGHSHARE MIXERS RMM

**RMM** ploughshare mixers are offered in several versions and materials of construction depending on the material nature. The main characteristics are:

1. Standard execution in mild steel or st. st. AISI 304/AISI 316 (optional) or Hardox Carbon steel (optional).
2. Inlets and outlets having shape in reference to the layout of installation.
3. Shaft and ploughs made of high resistance micro-alloy carbon steel, st. st. AISI 304/316 (optional) or Hardox Carbon steel (optional).
4. No mechanical parts in direct contact to mixed and conveyed product.
5. High speed.
6. Entirely sealed unit for leakage and odour-free environments.
7. Possibility to discharge in hoppers, screw conveyors, belt conveyors.
8. Extremely easy to mix materials even of difficult composition.
9. Complete absence of emission of bad smells, as equipped with closing covers.
10. No nuisance or emissions.
11. Perfect mixing of the materials (even liquids as option).
12. Easy and quick maintenance.



**GENERAL DIMENSION DATA FOR PLOUGHSHARE MIXERS RMM**

The data in the chart is to be considered approximate; since the machine is able to process materials of different types and therefore of different organic compositions, take these values as illustrative references that must be clarified and requested from our Engineering - Sales department.



| RMM MODELS | A - mm | B - mm | C - mm | Ø - mm | CAPACITY - m³/h |
|------------|--------|--------|--------|--------|-----------------|
| RMM2000    | 2500   | 1000   | 1150   | 800    | 20              |
| RMM3000    | 3500   | 1000   | 1150   | 800    | 30              |
| RMM4000    | 3000   | 1250   | 1400   | 1000   | 40              |
| RMM6000    | 4000   | 1250   | 1400   | 1000   | 61              |
| RMM8000    | 4250   | 1500   | 1650   | 1200   | 82              |
| RMM10000   | 4750   | 1500   | 1650   | 1200   | 105             |
| RMM15000   | 6750   | 1500   | 1650   | 1200   | 160             |

**Fabricated parts material:**

\*Stainless Steel AISI304 / \*Stainless Steel AISI316 / \* Painted mild steel

**Shaft and ploughs material:**

\*Mild Steel / \*Stainless Steel AISI304 / \*Stainless Steel AISI316 / \*High resistance steel HRS

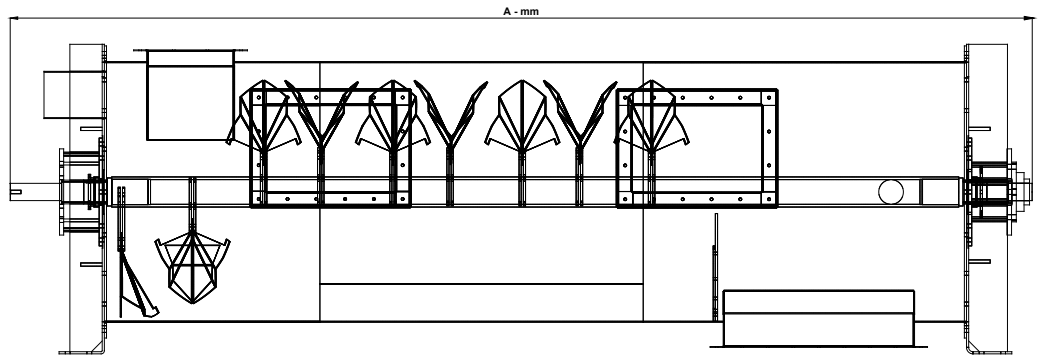
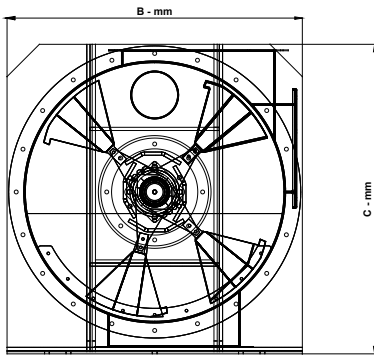

n.b.: the manufacturer may modify some dimensions or sizes without prior information

