

## POLYMER PREPARATION STATIONS STPL

### Polymer Preparation Stations for polymer powder

#### MACHINE DESCRIPTION

R.E.M. produce a wide range of sludge treatment units; the range here refers to:

- **Automatic Polymer preparation units - model STPL.**

The polymer preparation unit, mod. **STPL**, is used to automatically prepare polymer solutions which are used as coagulants for the suspended particles in the effluents treated in the waste water treatment plants. Polymer addition is used in the treatment of water both in the primary clarification-flocculation phase and in the last sludge dehydration phase.



The powder, fed by a shaftless screw feeder with integrated lump breaker, is dosed into the wetting and mixing cone in proportion to the water loaded in the tank. This special feature allows to control carefully the amount of powder optimising the process and reducing the powder consumption. The flowmeter installed at the water infeed measures the amount of water loaded in each batch. The value, preset by the control, is divided in 4 smaller batches.

Once calibrated the doser and set the concentration required, the system will calculate the amount of powder required and will dose the polymer necessary for the concentration in each fraction of batches. The pressurised water generates a funnel in the wetting cone and a vacuum effect which reduces the release of mist or humidity preventing the doser from clogging. The **3-tank** set-up allows to have a mixing tank, a curing tank and a feeding tank. An ultrasonic level control lets the customer control the exact amount of polymer in the feeding tank.

The control is entirely automatic and no manual valves or regulation are allowed reducing the risk of misplacement or incidents. The touchscreen control is very flexible and allows to control each parameter of the system including an Ethernet port for connection to the **SCADA system**.

#### WORKING LOGIC FOR AUTOMATIC POLYMER PREPARATION STATIONS STPL

The polymer make-up unit is used for the automatic preparation of polymer solution required as coagulants for the suspended particles present in the wastewater. The working logic is simple and reliable. The tank is always kept at the highest filling level. Once the level of the solution drops below the "low" level, the unit opens the intake solenoid valve and starts dosing the polymer.

The water is loaded in volume checking the right amount through the turbine flowmeter, while the polymer is dosed by time. A cross-check of the water flow is made to verify there is water in the line.



#### MAIN FEATURES MOD. STPL

1. THE WIDE RANGE OF PRODUCTS ALLOW TO CHOOSE THE CORRECT MODEL BASED UPON THE APPLICATION AND THE CHARACTERISTICS OF THE EFFLUENT.
2. THE UNIT MAY BE EASILY CLEANED BY USING PRESSURE WATER TO REMOVE SEDIMENTS OR LUMPS OF POLYMER NOT PROPERLY DISSOLVED.
3. THE UNIT IS ENTIRELY CLOSED BY COVERS WHICH MAY BE OPENED FOR INSPECTION. THE PRESENCE OF COVERS PREVENTS THE RELEASE OF ODORS OR SPILLAGES.
4. THE ENTIRE PROCESS IS AUTOMATED.
5. THE INSTALLATION IS SIMPLE AND FAST.
6. WHEN REQUIRED, MAINTENANCE IS PRETTY SIMPLE.

R.E.M. STPL polymer preparation units can be equipped with the following accessories:

- ATEX or UL NEMA 7 EX-proof version.
- UL version.
- Combined system with powder and emulsion dosing.
- Vacuum loading system.
- Big-bag emptying system.
- Ladder with platform.
- Dosing pump.
- Magnetic flowmeter.

**STANDARD DIMENSION DATA FOR AUTOMATIC POLYMER PREPARATION STATIONS STPL**

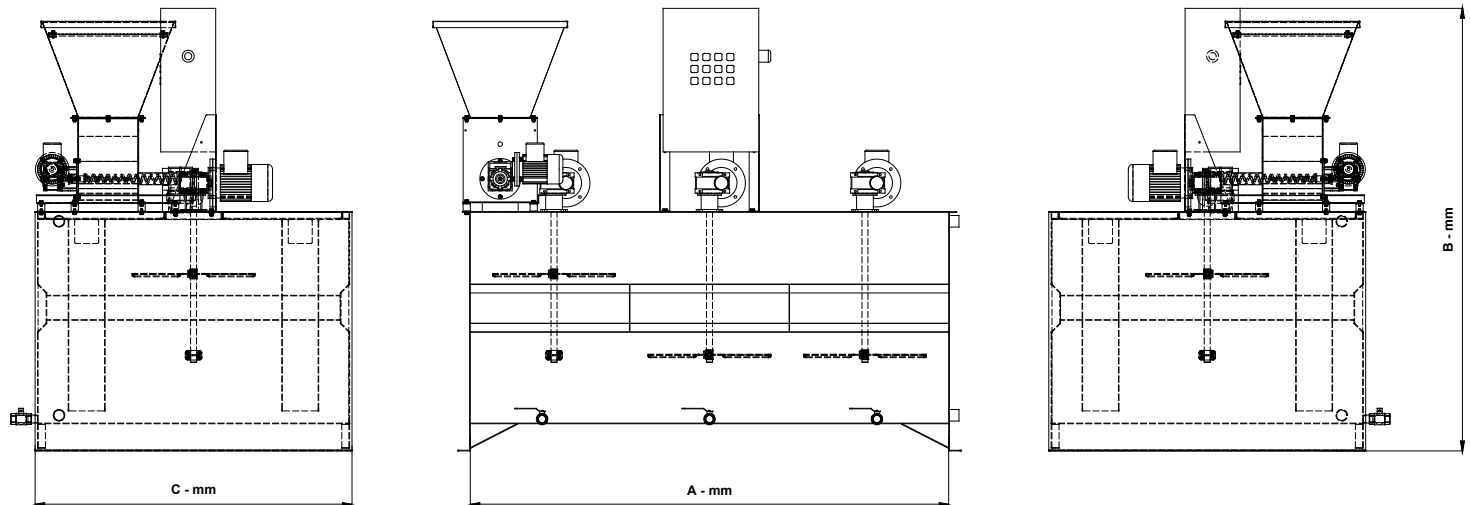

Fabricated parts material: \*Stainless Steel AISI 304 / \*Stainless Steel AISI 316

Wetting group material: PVC

n.b.: the manufacturer may modify some dimensions or sizes without prior information

STPL MODELS	STPL750	STPL1000	STPL1500	STPL2000	STPL2500	STPL3000	STPL4000	STPL5000	STPL7000	STPL10000
A - mm	1500	2000	2000	2000	2000	3000	4000	4000	6000	6000
B - mm	1666	1666	1666	1666	1666	1666	2216	2216	2216	2216
C - mm	825	825	1075	1325	1325	1325	1325	1325	1325	1725
Hopper capacity - kg	30	30	30	30	30	30	50	50	50	100
Hourly capacity - l/h	750	1000	1500	2000	2500	3000	4000	5000	7000	10000
Dry weight - kg	300	450	450	450	560	600	680	700	750	1200

